

TRACKED JAW CRUSHER

EXPECT SMOOTH OPERATION  
FROM THE **1060j-t**



**LIPPMANN**

# Outdoes the Competition

## 1060j-t

Crushing operations looking for mobility and crushing Capacities in excess of 400 TPH in one product turn to the Lippmann 1060j, one of the most powerful in the jaw crusher product range. The 1060j is designed to maximize output of high quality material, with a heavy duty build and high quality wear parts and components to minimize downtime.

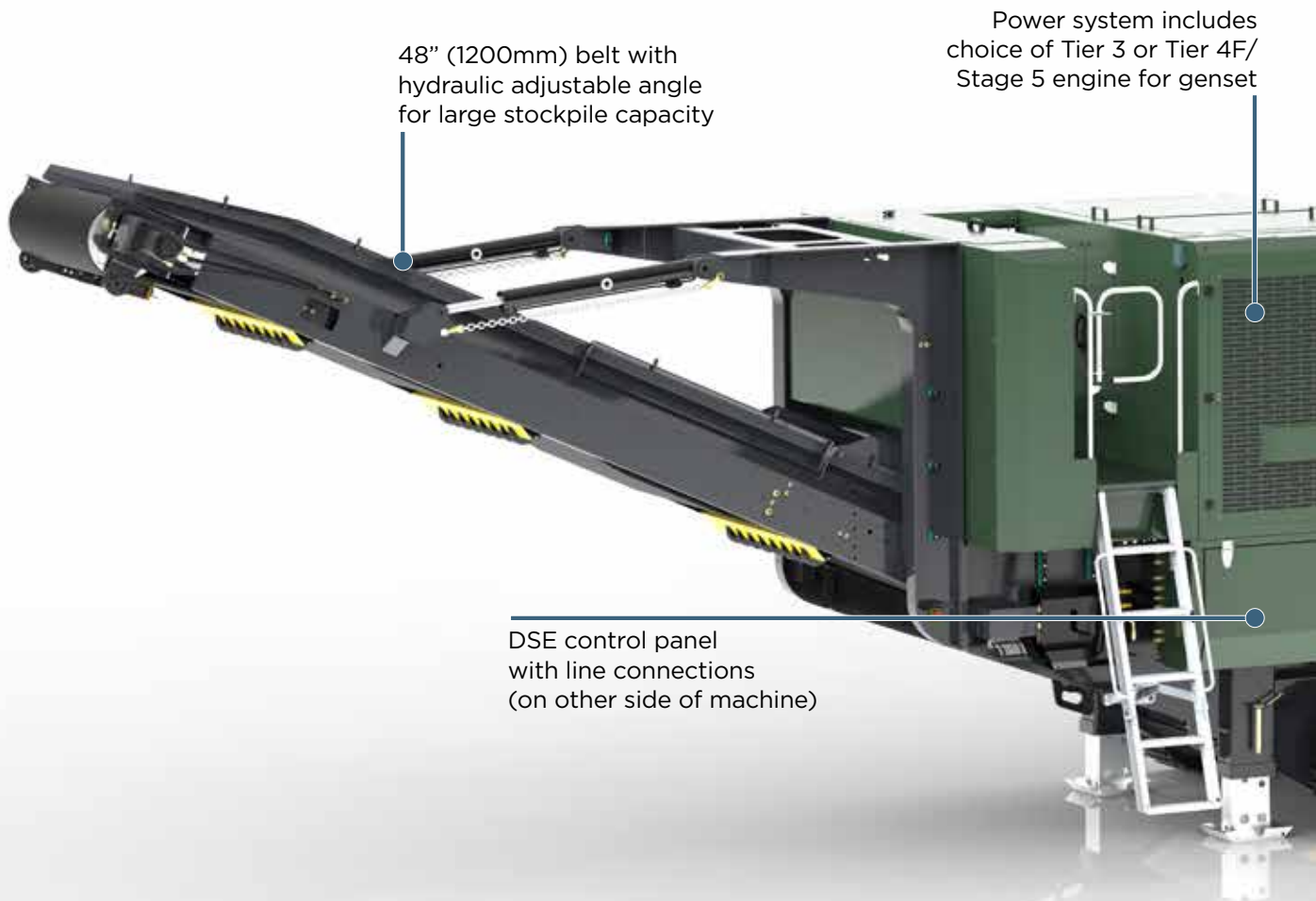

48" (1200mm) belt with hydraulic adjustable angle for large stockpile capacity

Power system includes choice of Tier 3 or Tier 4F/ Stage 5 engine for genset

DSE control panel with line connections (on other side of machine)



### POWER CHOICE

Operators have the option to run jaw plant models either through an on-board generator or by connecting to line power. Whatever you decide, you'll find your jaw crushers run smoothly and efficiently while taking reliability to new levels.

### STANDARD FEATURES

- 1060mm wide x 700mm single toggle jaw
- Choice of CAT or Volvo, LRC or T4F/Stage V engines
- HD crawler tracks
- Fast setup time
- Integrated hydraulic folding hopper
- Integrated hydraulic folding stockpiling conveyors
- I-beam plate fabricated chassis construction
- Quick release jaw for transport
- Large gap between crusher discharge and main conveyor feedboot
- Open chassis design for ease of maintenance



High inertia single toggle 42" x 28" (1060 x 700mm) jaw with heavy-duty bolted construction

Hydraulic fold and wedge lock hopper, optional extensions

Open chassis design for ease of maintenance

Heavy duty bolt-on tracks with smooth start/stop 3-speed system

Hydraulic jacking legs



Deep jaw chamber with single toggle design accommodates hard rock applications and large feed sizes. Also features closed side setting adjustment with hydraulic wedges.



Double deck grizzly pre-screen featuring hydraulic fold and wedge lock hopper, and optional cassettes - punch plate or fingers.



The large gap between crusher discharge and main conveyor belt, paired with wide main and side conveyors result in an optimized material flow.

# 1060j-t TECHNICAL SPECIFICATIONS

SPECIFICATIONS	
Feed Opening	42" (1060mm)
Crusher Drive	Hydraulic - V-Belt
Min. Opening	2.8" (70mm)
Max. Opening	8" (200mm)
CSS Adjustment	Hydraulic Wedges
Level Sensor	Ultrasonic

HOPPER	
Hopper Length	13' 8.3" (4175mm)
Hopper Width	8' (2342mm)
Hopper Volume	7.6 yd <sup>3</sup> (5.8m <sup>3</sup> )

FEEDER	
Feeder Width	41.9" (1064mm)
Adjustable Speed	YES - Via Electrical Proportional
Drive	Hydraulic

TOTAL WEIGHT	
Total Weight	106,900 lbs (48,500kg)

ENGINE	
Engine Option 1	Volvo D11 T4F/Stage V, 360 hp (270kW)
Engine Option 2	CAT C9.3B T4F/Stage V, 416 hp (310kW)
Engine Option 3	CAT C9.3 LRC, 416 hp (310kW)
Engine Speed	1800 rpm
Fuel Tank Capacity	141 US gal (535L)
Hydraulic Tank Capacity	272 US gal (1030L)

DIMENSIONS	
Transport Length	53' 2" (16.20m)
Transport Width	9' 6" (2.90m)
Transport Height	11' 5.8" (3.50m)
Operating Length	50' 8" (15.44m)

CONVEYOR	
Stockpile Height	12' 10" (3912mm)
Belt Width	48" (1200mm)
Angle Adjustable	YES
Quick Release	YES

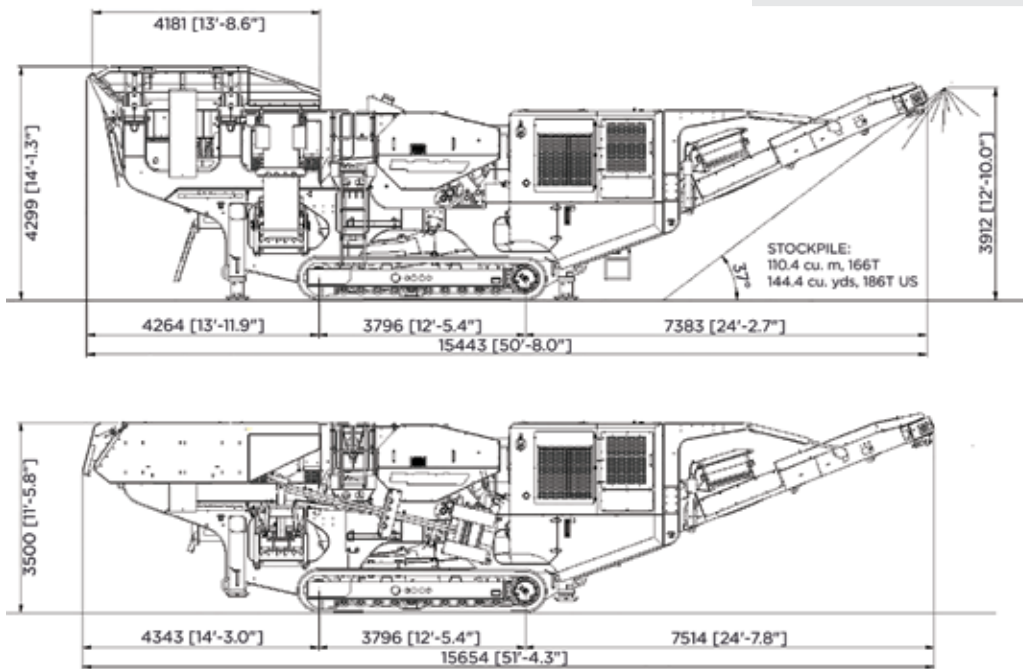

Lippmann reserves the right to make changes to the information and design of the machines on this brochure without reservation and notification to the users. Information at time of print considered accurate - Lippmann assumes no liability resulting from errors or omissions in this document.

## LIPPMANN

3271 East Van Norman Avenue  
Cudahy, WI 53110-0586 USA  
[Lippmann-Milwaukee.com](http://Lippmann-Milwaukee.com)  
800-648-0486

Lippmann European Office  
47 Moor Road  
Coalisland, Co. Tyrone BT714QB Northern Ireland  
[LippmannGlobal.com](http://LippmannGlobal.com)  
(+44) 28-8774-0926

AUTHORIZED DISTRIBUTOR